

Exhibitor Manual of Art Shenzhen 2017

1. Basic information

Art Shenzhen 2017

Host:

The Organizing Committee Office of China (Shenzhen) International Cultural Industries Fair

Organizers:

Shenzhen Press Group

Shenzhen International Cultural Industry Fair Co., Ltd.

Co-organizers (Strategic Partners):

TBC

Venue: Hall 6, Shenzhen Convention & Exhibition Centre, Fuhua 3rd Road, Futian District, Shenzhen

2. Events and Schedule

Events (TBC):

It is subject to the events released officially by the organizer.

Time: (3.5 days for exhibition period, 2.5 days for Move-in and Move-out period)

Exhibition Period: 15th -18th, Sep, 2017

Exhibitor Registration:

Time: 10:00pm, 14th – 9: am, 15th, Sep, 2017

Place: 206, SZCEC

Move-in: 14:00-23:00, 14th, Sep, 2017

09:00-14:00, 15th, Sep, 2017

Move-out: 16:00-20:00, 18th, Sep, 2017

VIP Preview: 15:00-21:00, 15th, Sep, 2017

Open Time: 10:00-19:00, 16th -17th, Sep, 2017

10:00-16:00, 18th , Sep, 2017

3. Exhibitor Introduction

1) Participating Procedures

- a. Exhibitor should submit *Booth Application Form* and *Exhibition Plan* during the valid period required by the organizer.
- b. The organizer will sign the exhibition contract after verification. Booth cost should be paid within stipulated time of the contract.
- c. Relevant exhibition materials should be submitted by 20th, Aug, 2017, including the *Construction Requirement Form*, etc. Exhibitor should ensure the facticity of all submitted materials and the original artworks. If any false or fake information found, or exhibitor fails to abide the rules and regulations of the contract, in this case, the organizer owns the right to invalidate the booth application and will not refund the payment.
- d. Any loss caused by exhibitor for not abiding the rules and regulations

should be borne by the exhibitor.

- e. The organizer owns the right to require the applicant to provide detail information about any artwork and forbid displaying any artwork which does not match with the requirements of the exhibition.

2) Payment

Booth cost should be paid to appointed account by stipulated time. The date of payment is subject to the paying check or TMO confirmed by the bank. Otherwise, the organizer owns the rights to terminate contract and re-arrange the booth for other exhibitor. After receiving booth cost, the organizer will immediately inform the exhibitor and present the receipt voucher.

If the exhibitor fails to move-in within required period, the organizer reserves the final rights to terminate contract. In this case, exhibitor will be responsible to bear full booth cost and other extra fees.

After signing the contract and paying booth cost, if exhibitor has to quite for special reasons, it will be refunded as below:

Before 15th, July, 2017, full payment refunded;

Before 20th, July, 2017, 50% payment refunded;

After 1st, Aug, 2017, no payment refunded.

3) Booth Arrangement

The Academic Committee and the organizer have the final decision rights to arrange the booths. Details about the booth please refer to the contract

and booth plan.

4) The Use of the Booth

It is prohibited to sublease the booth or share the booth with others in any ways, display any exhibits out of the *Application Form* or any artwork without marking its artist's name as well. Moreover, all exhibits can be displayed inside the booth only and no artist performance is allowed on the booth. Considering the safety of exhibits, exhibitors cannot withdraw from the exhibition midway, leaving the booth unattended for any reasons.

5) The Design of the Booth

The booths will be constructed by the constructors appointed by the organizer. According to the safety requirements of construction, exhibitor can have special design for his/her booth. The organizer owns the rights to prohibit any booth designs that do not match the whole image of the exhibition or safety requirements.

After confirming the booth, if exhibitor needs anything else besides the standard facilities on the booth, it must be approved by the organizer.

Exhibitor needs to fill the *Application Form of Extra Service*, submit it to the constructor and pay all relevant cost.

No displaying board and spot light added and moved after move-in. If any extra service needed, the organizer will charge extra cost for the service.

Booth design requirements:

- a. Displaying board with one-end attached only: displaying board with one-end attached only cannot be longer than 3 meters (9.8 inches) as below:

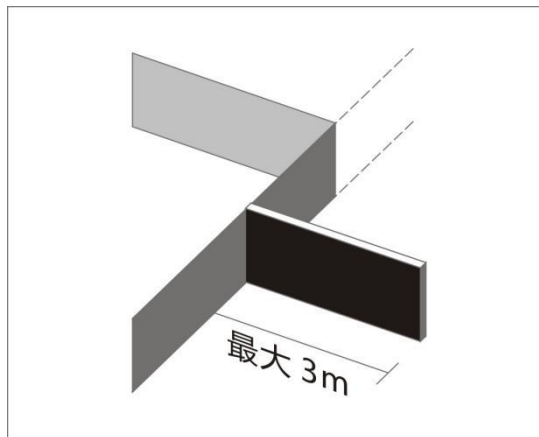

- b. Displaying board with two-end attached: displaying board longer than 5 meters (=16.4 inches) must be two-end attached. Add a wall (at least 2 meters long) to the other end, standing perpendicularly to the displaying board, shaping as 'L' or 'T'. The length between two parallel walls is not longer than 6 meters (16.7 inches). (See as below)

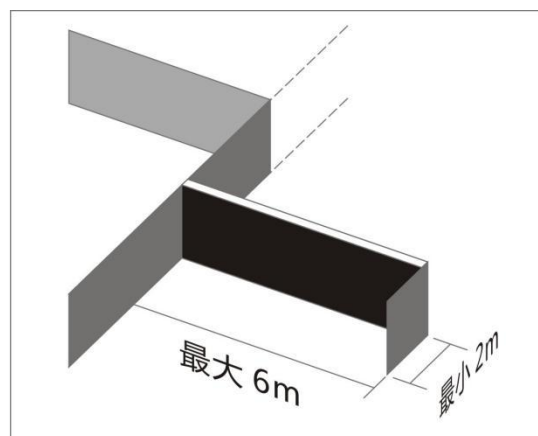
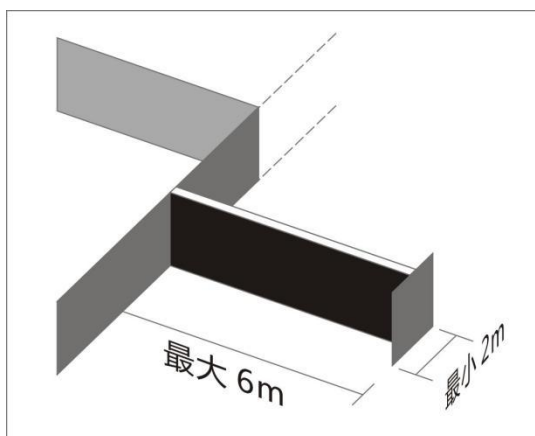

- c. Displaying board without attachment: Because of its instability,

displaying board without attachment is not allowed as below:

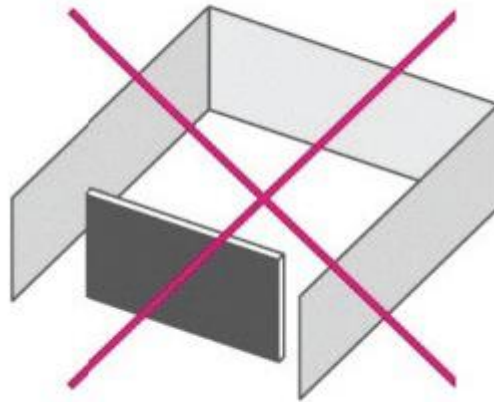

d. To fasten a displaying board: exhibitor can choose to add two boards perpendicularly to both two ends of the displaying board as below (to shape as 'TL' or 'H').

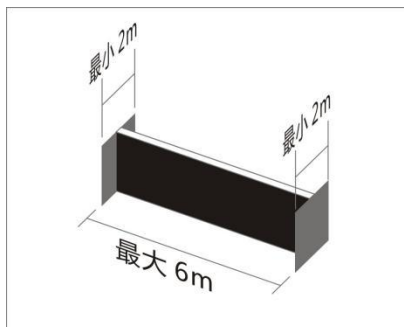

Shaped as 'H'

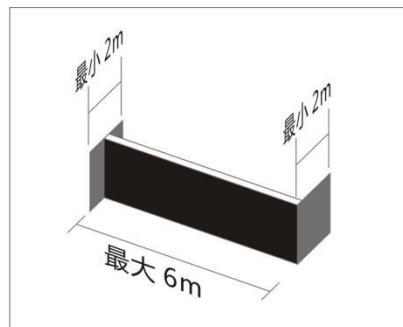

Shaped as 'TL'

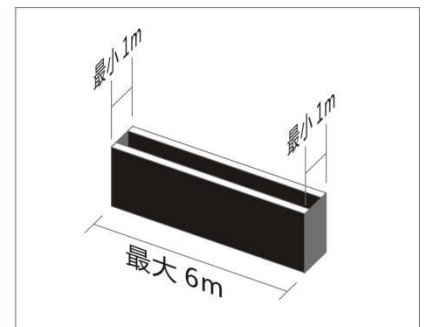

Shaped as 'box'

For raw-space:

1. Booth design sketch and the information of construction materials must be submitted to the constructor for verification before 15th, Aug, 2017.

Construction material like KT board is prohibited at the exhibition.

2. Exhibitor should bear relevant exhibition fees, including the management fee for raw-space, electricity fee and overtime service fee for move-in and move-out.

6) The Catalogue of Art Shenzhen

Every exhibitor will be in the catalogue as below:

- a. Booth size smaller than 50 m² (50 m² included) will get 2P catalogue with the introduction of exhibitor and exhibits;
- b. Booth size over 50 m² and smaller than 120 m² (120 m² included) will get 4P catalogue with the introduction of exhibitor and exhibits;
- c. Booth size over 120 m² will get 6P catalogue with the introduction of exhibitor and exhibits and get 2 catalogues for free .

To make it perfect, the catalogue will be edited by the organizer all alone.

There will be 1-2 photos (over 300dpi) for exhibits in each page.

Exhibitors should submit the introduction and photos before 20th, Aug, 2017, and overtime submitting is not accepted.

7) Cleanness

During the exhibition period, the organizer will only be responsible for cleaning public space (passages included) and exhibitors need to finish cleaning the booths before the open time every day.

The cleaning work in the public area during the exhibition arrangement and dismantling periods shall be arranged by the ICIF Organizing Committee, while the exhibitor shall be responsible for the cleaning of his own booth. Exhibitors should finish cleaning the booths before the open time every day. After the exhibition, exhibitors should take the package

material and other garbage away from the booths.

8) Publicity

The organizer will release relevant information of the exhibition through mass public media, including general introduction of the exhibition and part of exhibits, and also arrange interviews and news reports to exhibitors during the exhibition. All exhibits will be shown successively with their organizations' website links on the 'News' area of the official website of Art Shenzhen (en.artshenzhen.com).

9) Recordation and Shipping for Overseas Exhibits

Recordation: According to state regulations, overseas exhibits of art exhibition (including overseas, Hongkong, Macao and Taiwan region) should be submitted to related department for recordation and verification. Shenzhen Customs District People's Republic of China will check the conformity of all the exhibits on the basis of this record.

According to the schedule of the exhibition, exhibitor needs to contact a forwarder that can help to handle all customs formalities and exhibits shipping problems. Meanwhile, every exhibitor should submit the exhibits' integrated pictures and description (including the name of the author and the exhibit, size, material, production year, and brief introduction of exhibitor, please also indicate the content if the exhibit is with litera) to the organizer before 15th, Aug, 2017. According to the requirements of Shenzhen Customs District People's Republic of China,

those materials shall be on-site recorded by the customs stagnation point at Shenzhen Convention and Exhibition Center. Once the materials submitted, they cannot be modified or changed.

Customs Declaration and Shipping:

Exhibitors shall bear any related loss for all the consequences caused by the failure to provide correct and complete information during the process of customs formalities. The organizer shall only be responsible to provide any possible assistance and communications.

10) Exhibit Storage

The management organizations of the exhibition will not be responsible for the reception and storage of exhibits or booth construction material. Exhibitors shall arrange their own staff to take charge of this. Any storage service needed, please contact the storage center of Shenzhen Convention and Exhibition Center. (Contact No.: 0086755-82848646 Mr. Chen)

11) Security

The organizer will offer security guard service for the public space of the exhibition hall. Every exhibitor must be responsible for the damage risk of their booth by themselves. The organizer and other staffs shall not be responsible for the damage of the exhibitors' goods and equipments. Every exhibitor shall cover its exhibits and valuables with insurance to safeguard against losses arising from theft, loss, fire, etc.

During the exhibition period, no exhibits can be allowed to move out any

without the permission of the organizer. In order to maintain the safety and order of the exhibition, exhibits should leave the Center with an Item Release Pass issued by the office of the ICIF Organizing Committee, which shall be signed or sealed by the onsite person in charge. Exhibits will be released after the approval by the organizer and security department.

During the exhibition arrangement and dismantling period and the exhibition period, exhibitors and all staff can only move around at the Center with relevant permits issued by the organizer.

24 hours professional security service will be provided in the exhibition halls from the first move-in day to the last move-out day. During the exhibition arrangement & dismantling period and the exhibition period, every exhibitor shall be responsible for the security of their own exhibits, and security will guard the exhibits after the halls closed.

Exhibitors shall follow the regulations of fire, safety and security. Every exhibitor shall bear any damage and loss caused by their own negligence or failure to follow or violation of the regulations. And every exhibitor shall pay compensation to the organizer or the third party for all or part of damage and loss.

12) Insurance

Every exhibitor can arrange insurance to safeguard the exhibits during the exhibition period, and it will cover the damage and loss for the exhibits

transportation in hall, all of the exhibits, equipments and related staff during the exhibition arrangement & dismantling period and the exhibition period. Every exhibitor shall follow the safety rules and buy full value insurance for the damage caused by fire, stealing, damage, flood and transportation.

13) Intellectual Property Rights

Every exhibitor shall undertake that all the exhibits and all the submitted materials will not be infringement of the third party's intellectual property right. If there is any infringement upon copyright or other intellectual property rights caused by the exhibitor's own negligence or fault, the exhibitor shall bear all the liability, and indemnify the organizer against any loss, damages, costs, expenses or other claims arising from any such infringement.

14) Related Service

The organizer will recommend service providers of shipping, interpretation, portage and travelling for reference to select. (Please see the attachment for the list.) All expense shall be borne by the exhibitors.

15) Force Majeure

As any non-human factor accidents outside the control of the organizer occurred, including (but not limited to) earthquake, fire, riot, war, strike, epidemic, economic or political turmoil, etc., the organizer has the right to cancel, delay or shorten the exhibition. In this case, every exhibitor

shall not get refund for any payments, and every exhibitor shall not claim for the loss caused by force majeure to the organizer.

16) Obligations of Exhibitor

Every exhibitor shall not eat or smoke in the booth. During the exhibition period, every exhibitor shall follow all the exhibition rules at any time, including the terms of site tenancy, *The Exhibition Instructions for Exhibitor* and *Exhibitor Manual* published by organizer.

Every exhibitor shall move-in & move-out in the regulated time. Any overtime expense caused by the overtime arrangement shall be paid by the exhibitor.

Every exhibitor shall supervise his/her staff, invited guests and cooperation partners (e.g. transportation contractors, construction companies, and etc) to co-comply with the terms of 'Art Shenzhen'.

Every exhibitor shall assume full liabilities and bear all the losses and damages arising from any damage behaviors and events for the organizer.

17) Electric Safety Management

During the exhibition period, all of the electronic equipments and lightings, except the standard power supply provided by the organizer, shall apply for electricity declaration no matter how large the power they are, and shall be connected by the organizer designated professional electrician. Every exhibitor is prohibited to engage in private connection.

The exhibition hall has the right to outage the power if private connection

is found, and the exhibitor shall pay for the related penalty.

18) Force of Law

These terms are the complete and final agreement between the organizer of 'Art Shenzhen' and the exhibitors. Any legal issues occurs during the execution will be applicable to *Law of the People's Republic of China*. Once any legal disputes occurred, organizer and exhibitors both agree to submit the dispute to the competent court.

The Organizer Contact Info

Performing organization: The organizing committee of Art Shenzhen

Shenzhen International Cultural Industry Fair Co., Ltd.

Address: 10F, Olympics Building, Economic Daily Road, Futian,
Shenzhen, Guangdong

Post code: 518034

Tel: +86-0755-83519273/83521084

Email: info@artshenzhen.com

Website: www.artshenzhen.com